

ATTENTION : Il existe 2 configurations au niveau de l'arbre de transmission et des joints d'étanchéité associés. Choisir parmi les repères 10 à 12 ou 20 à 23, selon la hauteur des **plats d'entraînement** de l'arbre de transmission sur votre machine.
h = 18,5 mm ; H = 25,5 mm

WARNING : There are 2 configurations regarding the transmission shaft and the associated seals. Choose among indexes 10 to 12 or 20 to 23, according to the height of the transmission shaft **driving flats** on your machine.

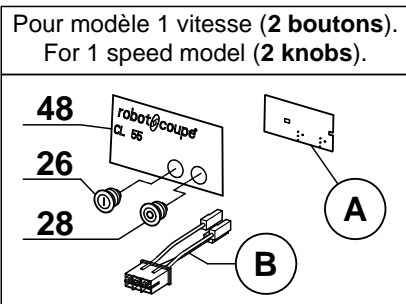

Uniquement pour moteur monophasé.
 Only for single phase motor.

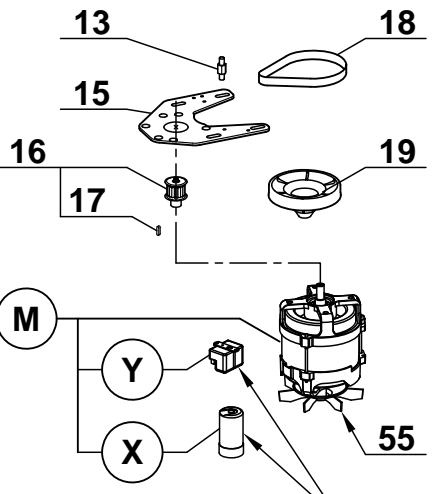
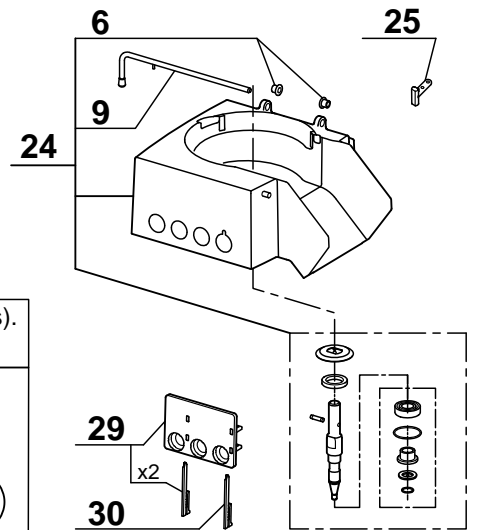
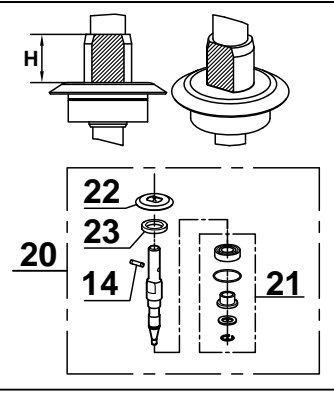
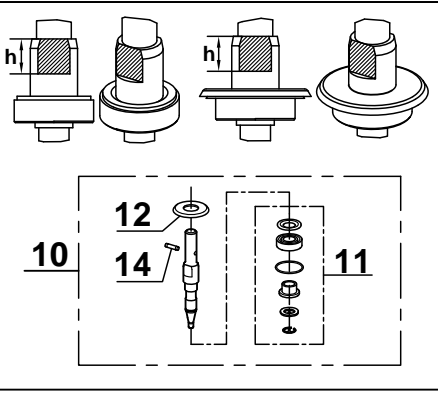